

# 339024

assembly instruction    manual de instrucciones    manuel des instructions    manual de instruções

1

1.208 x 2.083 x 528

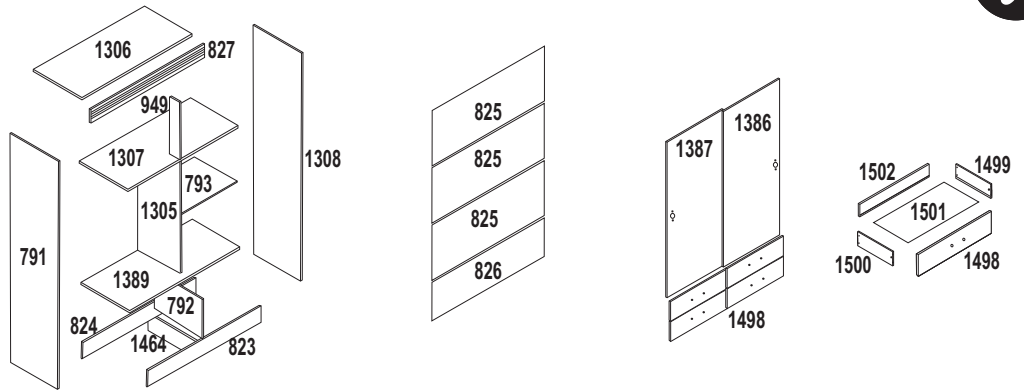
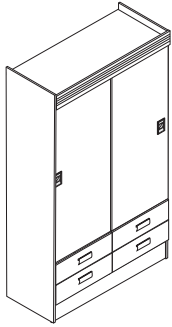

accessories    accesorios    accessoires    acessórios



2 - preparation of the pieces    preparación de las piezas    préparation des pièces    preparação das peças

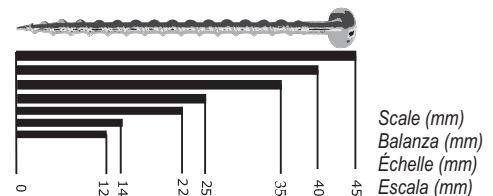
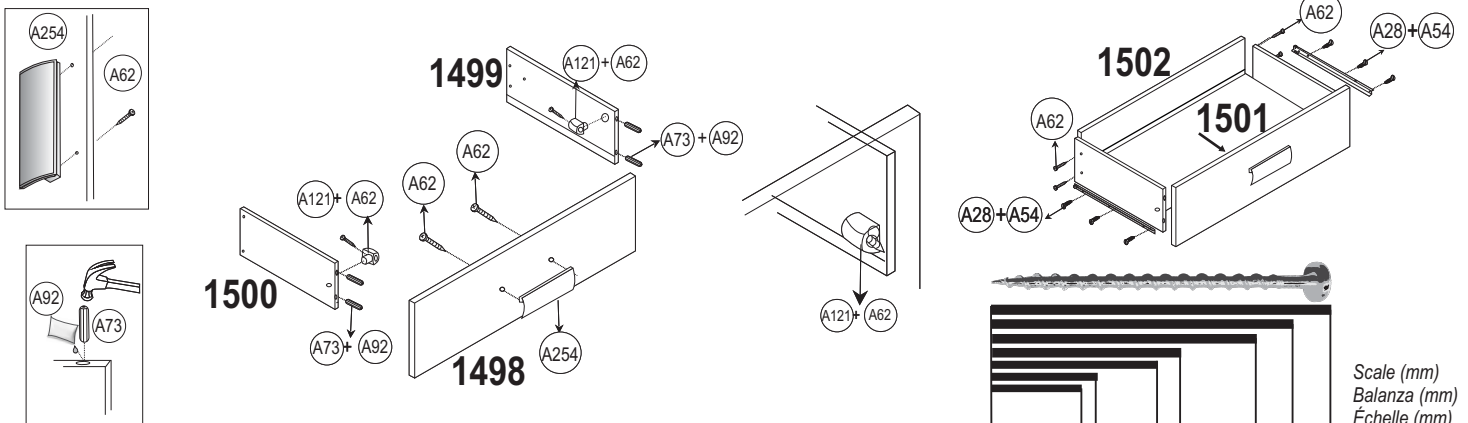
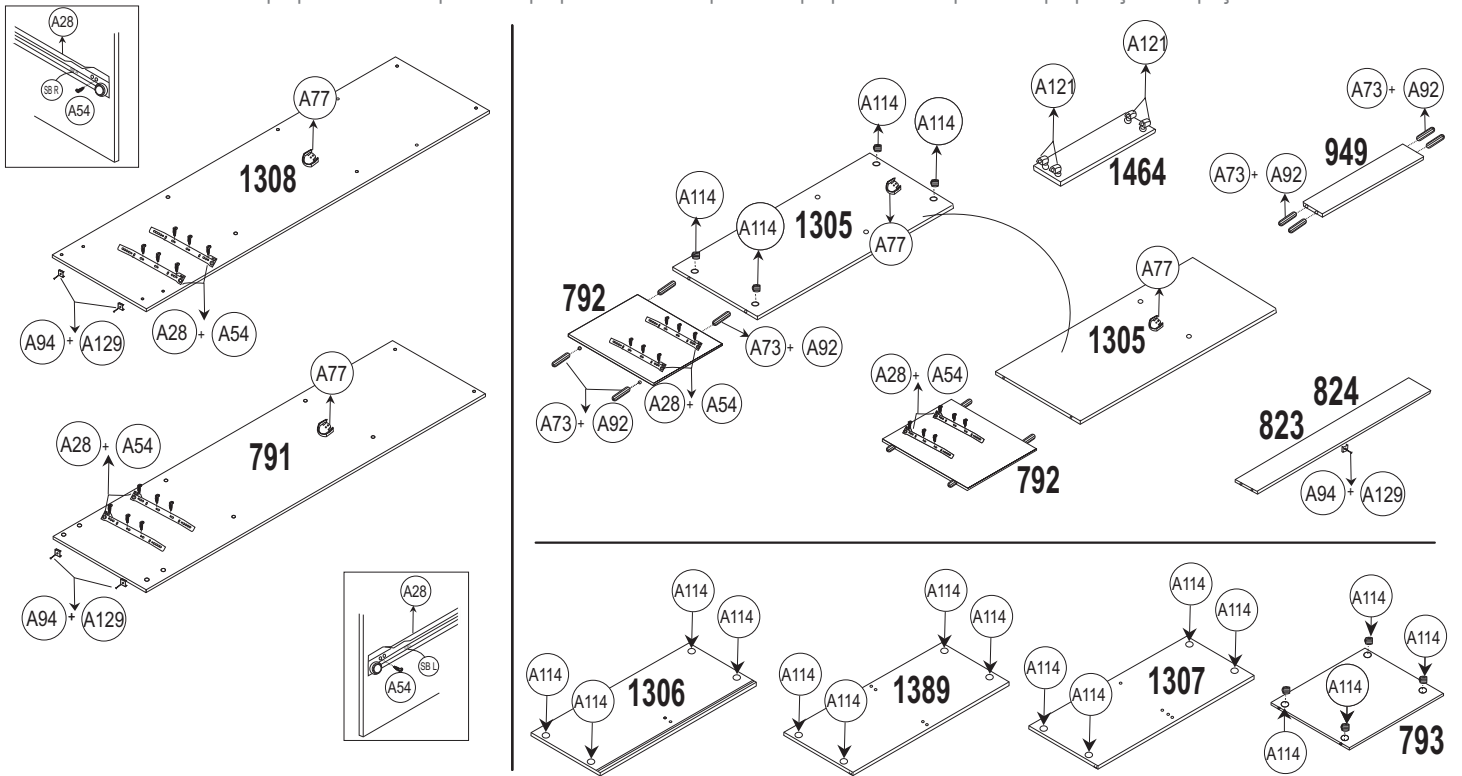

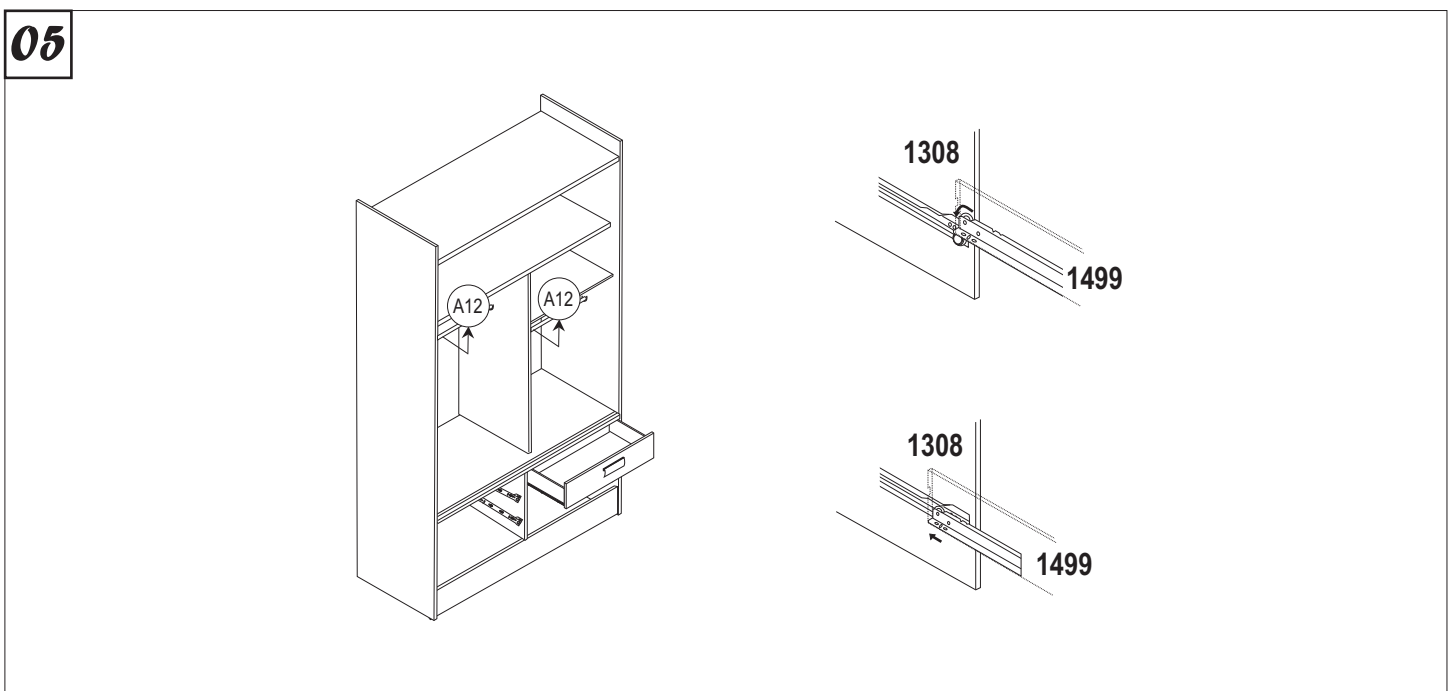
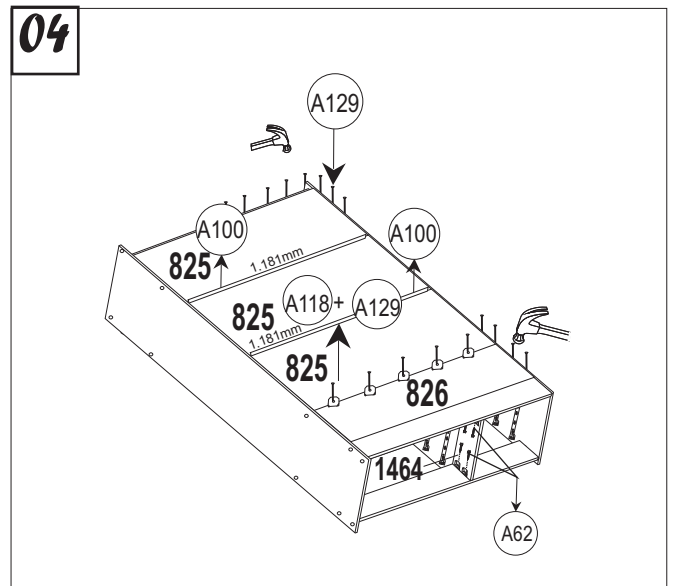
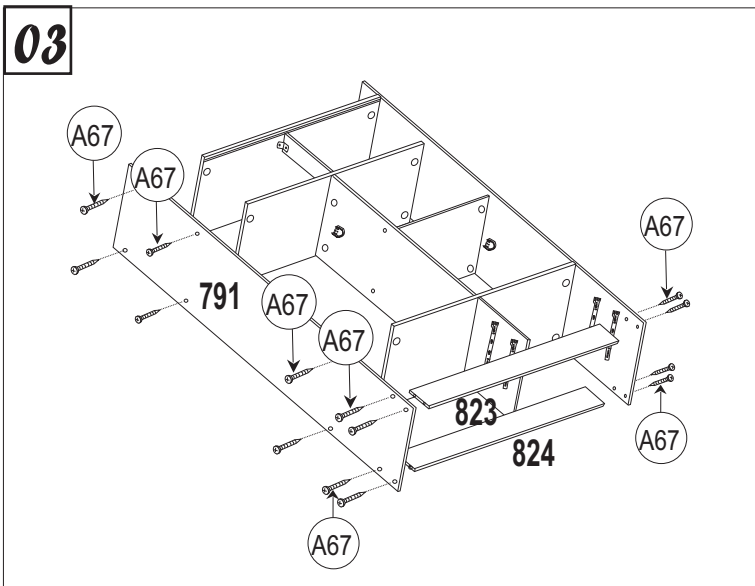
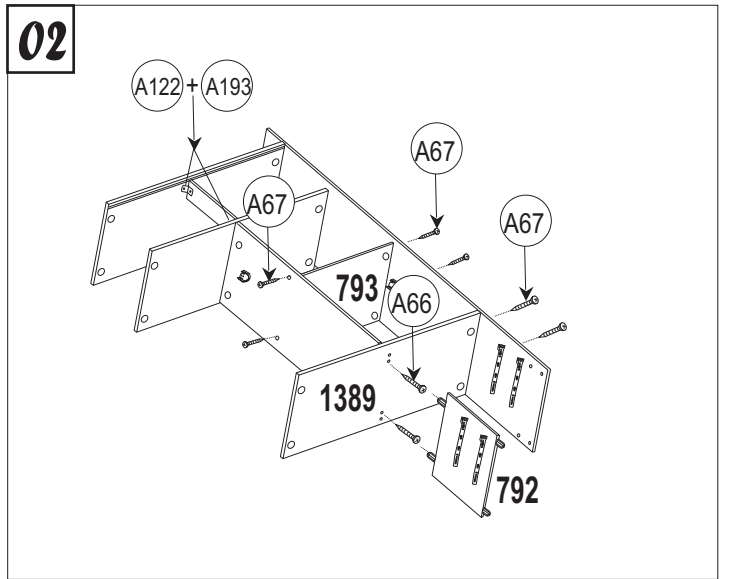
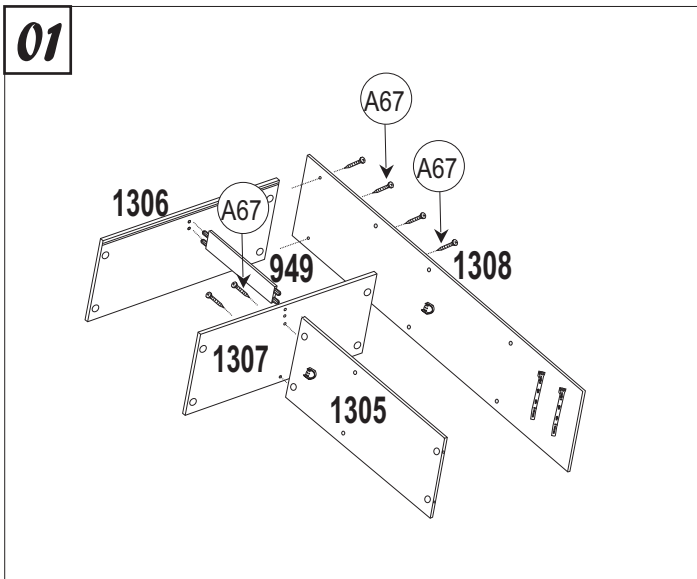

accessories    accesorios    accessoires    acessórios



**06**

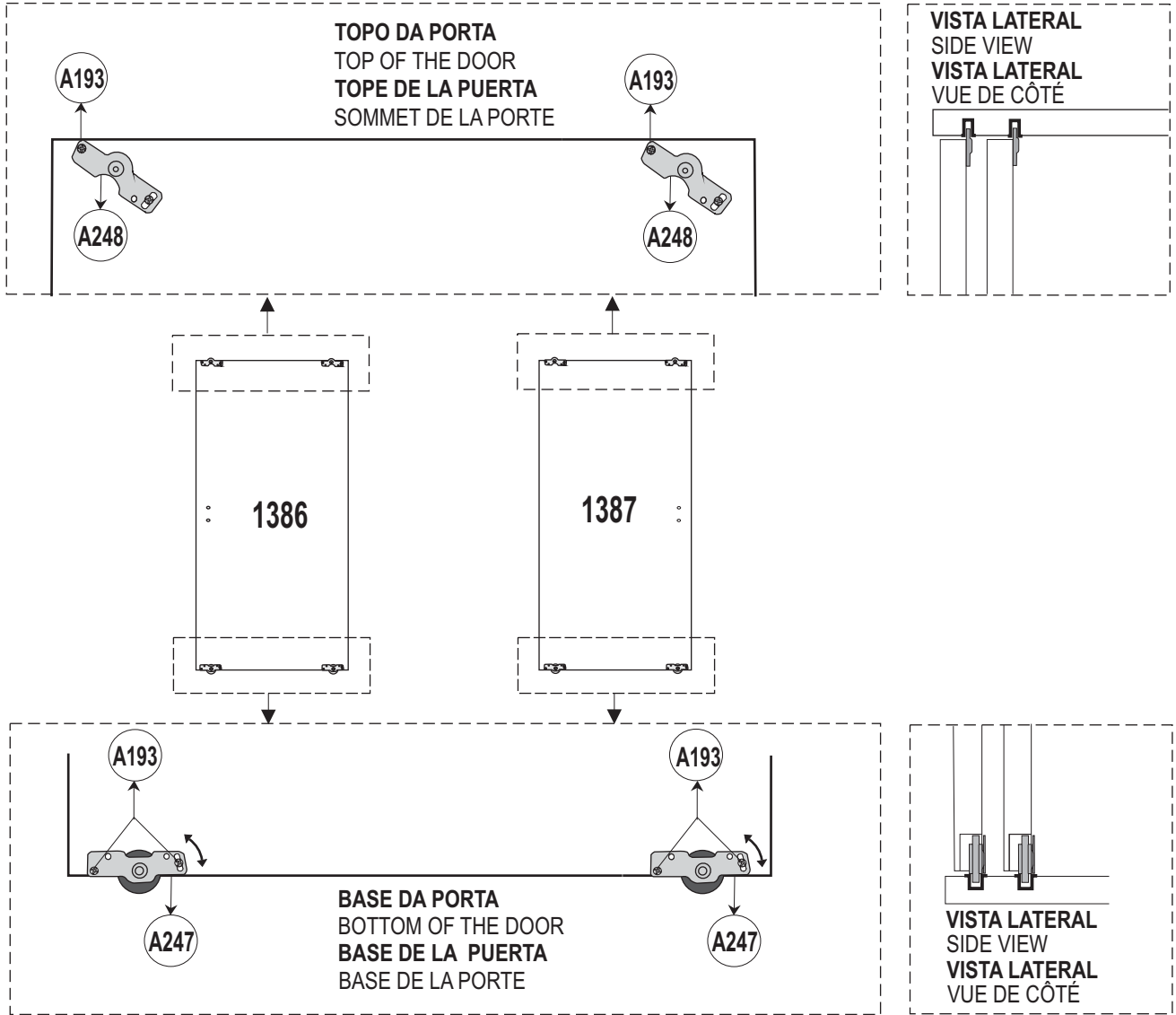

**07**

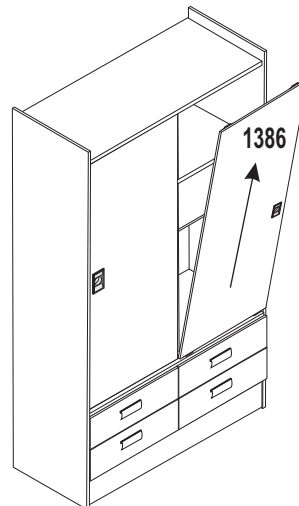
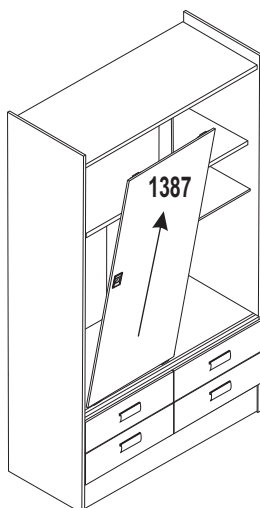

08

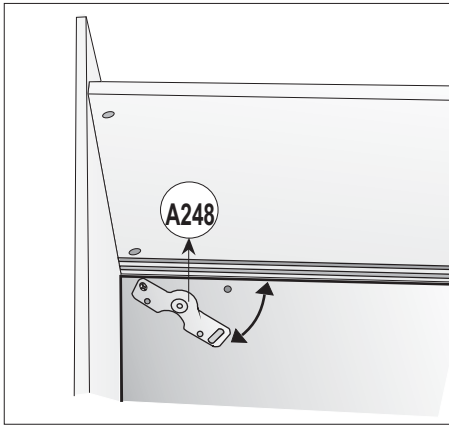

- FIXE A FERRAGEM A248 APENAS EM UMA DAS PONTAS.
- INSTALL THE HARDWARE A248 ONLY IN ONE SIDE.
- FIJE EL HERRAJE A248 APENAS EN UNA DE LAS PUNTAS.
- FIXEZ LA QUINCAILLERIE A248 SEULEMENT DANS UNE PORTE.

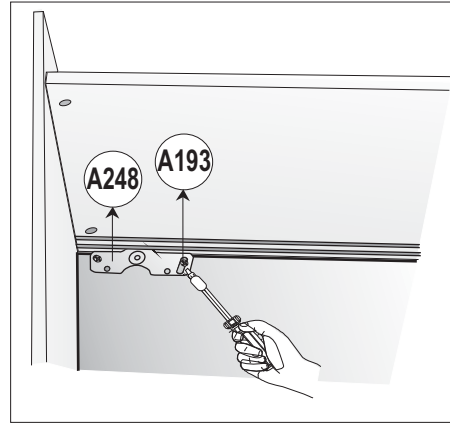

- APÓS POSICIONAR A PORTA, ENCAIXE A FERRAGEM A248 NO CANAL E FIXE A OUTRA PONTA.
- AFTER TO POSITION THE DOOR, PUT THE HARDWARE A248 ON THE GROOVE, AND THEN TIGHT THE OPPOSITE SIDE.
- DESPUÉS DE POSICIONAR LA PUERTA ENCAJE EL HERRAJE A248 EN LA CANALETA Y FIJE LA OTRA PUNTA.
- APRÈS POSITIONNER LA PORTE, EMBOÎTEZ LA QUINCAILLERIE A248 SUR LA CHAÎNE ET FIXEZ L'AUTRE PORTE.

09

- In order to let the doors perfectly leveled, please see the picture and adjust them using screw A193 from A247 hardware.

- Para ajustar correctamente la puerta, por favor observe la imagen. Para que las puertas queden en el mismo nivel el ajuste debe ser hecho por el tornillo A193 del accesorio A247.
- Pour ajuster correctement la porte, observez s'il vous plaît l'image. Afin que les portes soit au même niveau l'ajustement devrait être fait par la vis A193 de l'accessoire A247.
- Para o ajuste ideal das portas, observe a foto em destaque. Para que as portas fiquem no mesmo nível, o ajuste deverá ser feito através do parafuso A193 do acessório A247.

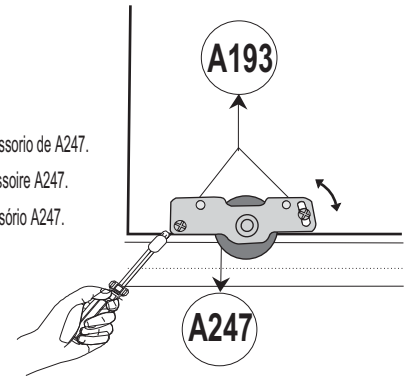

10

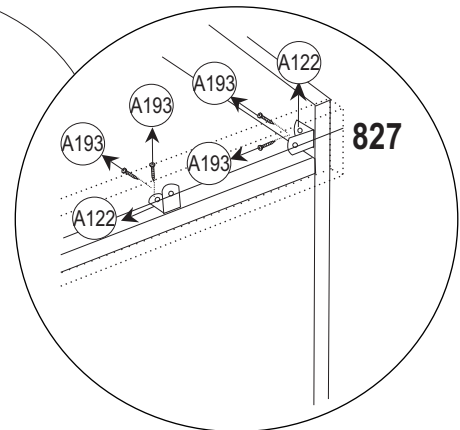
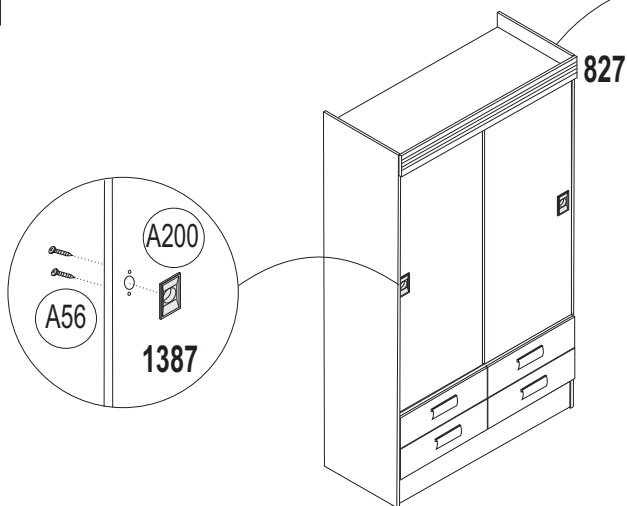

peça    piece    pièce    pieza

• Em caso de problemas técnicos com o móvel, favor informar o número de lote e data de fabricação, identificados nas bordas de alguns componentes dos móveis, para o rastreamento interno do produto e solução do problema.

• If technical problems happened, please find the lot number and manufacturing date, identified on borders of some furniture's pieces, to internal tracking and problem's solution.

• Dans le cas de problèmes technique avec le meuble, informer le numéro de lot et la date de fabrication, identifiées dans le cadre de quelque composant des meubles, permettant à nous identifier le produit et le problème.

• En caso de problemas técnicos, por favor informe el N° del lote y la fecha de fabricación identificada en el borde de algunas de las partes del mueble para la identificación interna del producto y la solución del problema.

